

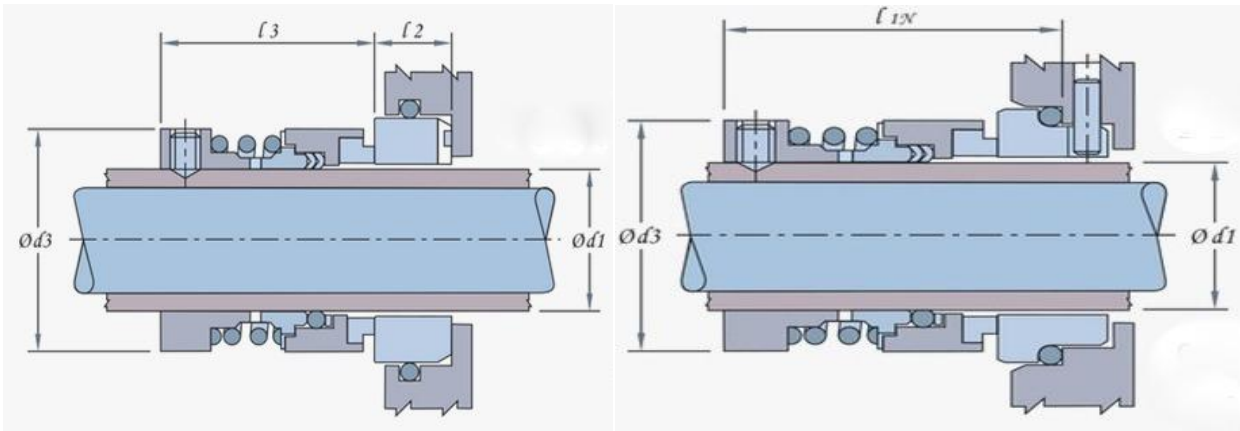

Single Spring Seal US 1507/1508



Dimensions (in mm):

d1	d3	l2	l3		d1	d3	l2	l3
22.22	36.6	11.1	36.0		53.97	69.8	14.3	56.0
25.4	39.7	12.7	39.5		57.15	73.0	14.3	56.0
28.57	42.9	12.7	39.5		60.32	77.0	14.3	56.0
31.75	46.2	12.7	39.5		63.5	80.8	14.3	56.0
34.92	49.2	12.7	44.5		66.67	86.2	15.9	66.0
38.1	52.4	12.7	44.0		69.85	89.4	15.9	65.0
41.27	55.7	12.7	44.0		73.02	92.5	15.9	65.0
44.45	60.0	12.7	49.0		76.2	95.7	15.9	65.0
47.62	63.2	12.7	49.0		79.37	100.1	15.9	74.0
50.8	66.4	12.7	46.0		82.55	104.5	15.9	74.0





d1	d3	l1N		d1	d3	l1N
25.0	39.7	50.0		53.0	69.8	70.0
28.0	42.9	50.0		55.0	73.0	70.0
30.0	46.2	50.0		58.0	73.0	70.0
32.0	46.2	50.0		60.0	77.0	70.0
33.0	49.2	55.0		63.0	80.8	70.0
35.0	49.2	55.0		65.0	86.2	80.0
38.0	52.4	55.0		68.0	89.4	80.0
40.0	55.7	55.0		70.0	89.4	80.0
43.0	60.0	60.0		75.0	95.7	80.0
45.0	60.0	60.0		80.0	100.1	90.0
48.0	63.2	60.0				
50.0	66.4	60.0				

